

K-U

2.1

3.1

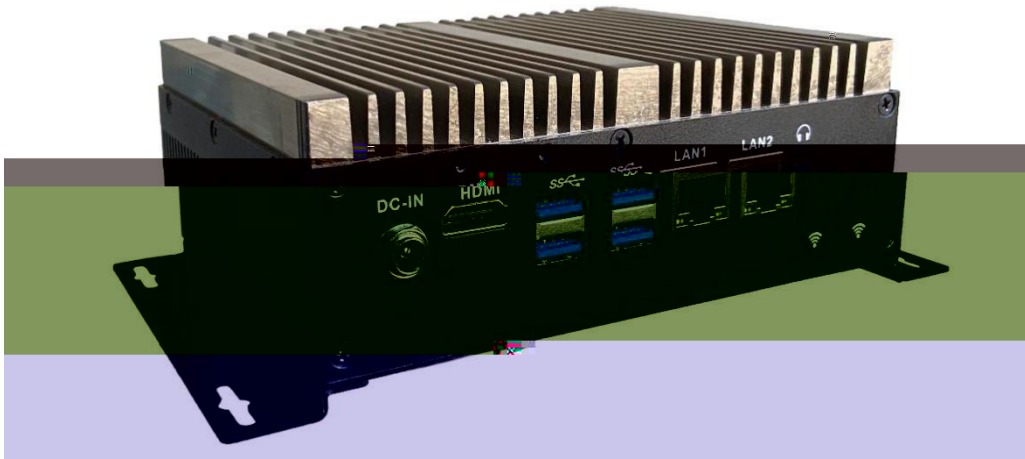

3.2

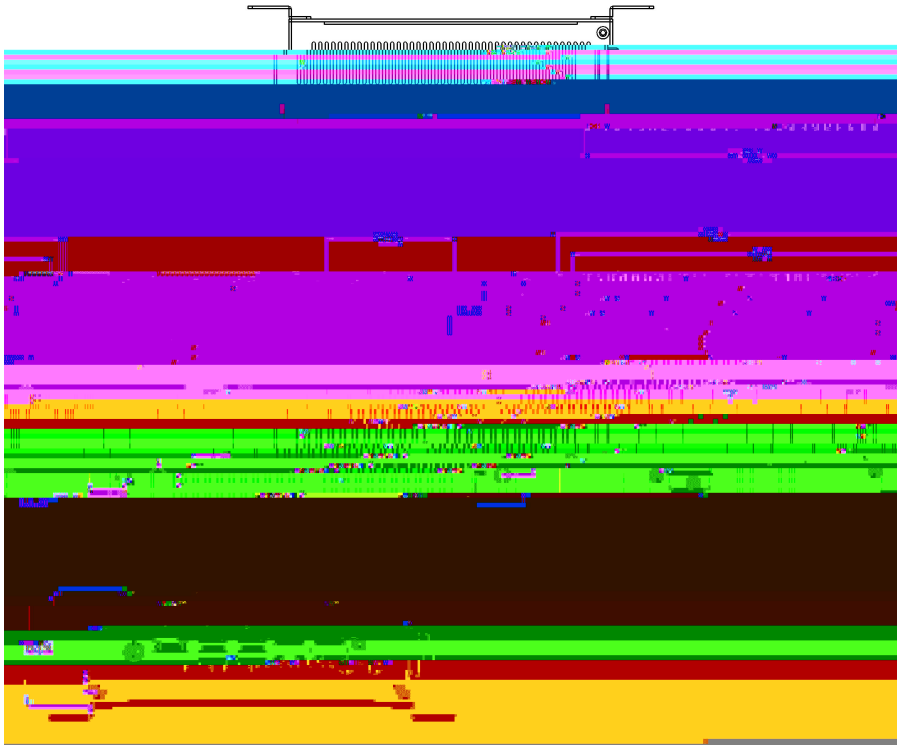

4.1

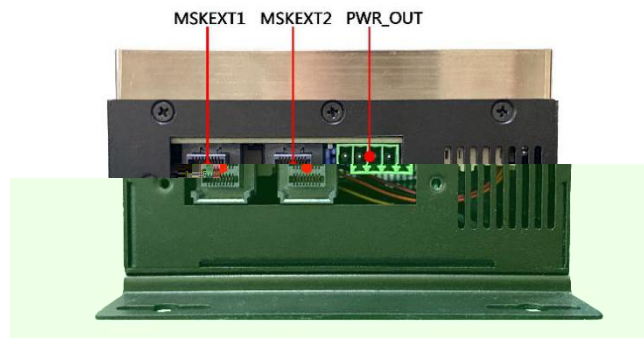
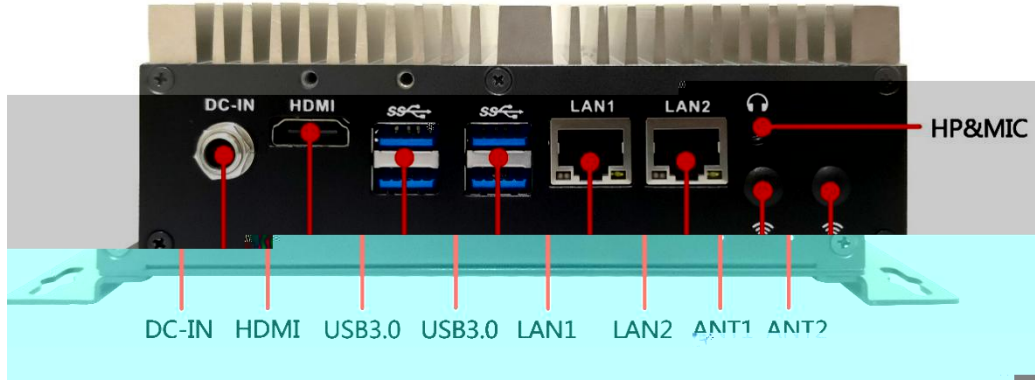

JP/CN	pin#	Signal	pin#	Signal
MSKEXT2				

- & 3.5

JP/CN	pin#	Signal
DC_IN		



JP/CN	pin#	Signal
PWR_OUT		

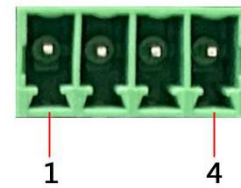



K-U89MSK BIOS

K-U89MSK BIOS